

DRIVE LINE SYSTEMS DLS

TRENDSETTING MODULES FOR ECONOMICAL DRIVES

- ▶ AGRICULTURAL PTO DRIVE SHAFTS
AND CLUTCHES





**TRENDSETTING MODULES
FOR ECONOMICAL DRIVES**



DRIVE LINE SYSTEM DLS

The components of our Drive Line System make life easy for you: they're simple to operate and straightforward to service. As a result, you save time and can rely completely on the performance and efficiency of your machine.

Knowing what's inside

Have you ever asked yourself what actually drives your valuable machines? No? Well, you really ought to. After all, the driveline is the heart of an agricultural machine. If it stops, so does the whole machine. And you have to deal with the driveline components every day: when hitching and unhitching the PTO drive shaft, or when greasing.

If there's a brand on it, there should be Walterscheid in it

Many manufacturers with high quality standards have the drivelines of their agricultural machinery developed by Walterscheid. You can tell our components by the stamped rhombus. When buying new equipment or spares, you too should pay attention to this quality symbol on PTO drive shafts, gearboxes and clutches. Because if the entire driveline comes from an experienced source, everything will run smoothly. A perfectly operating driveline protects your valuable equipment against wear and avoids breakdowns and repairs.

Skimping on the driveline means jeopardising your success

As a farmer, you naturally have to keep a close eye on your costs. In this context, remember

- › that Walterscheid has products optimally tailored to every performance range in terms of price and features,
- › that our components have the longest service life,
- › that Walterscheid overload clutches optimally protect your machine,
- › that driveline components of inferior quality cause long downtimes.

Then, you'll also know that it's worth while to invest in high-quality driveline components. And professionals can tell them by the stamped rhombus.

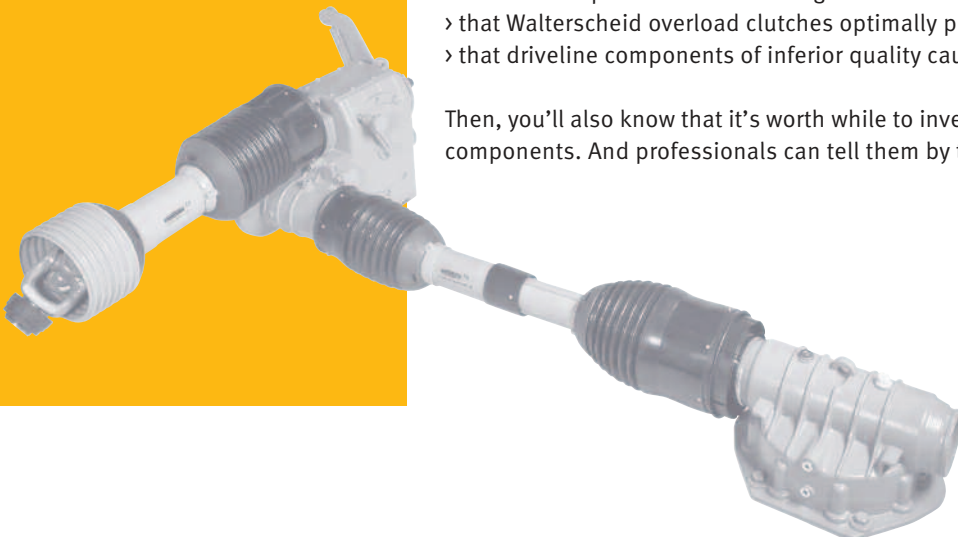



THE COMPONENTS OF THE DRIVE LINE SYSTEMS DLS

PTO drive shafts

At Walterscheid, you'll find the right components to fit any requirements profile – from a standard PTO drive shaft to the high-end Power Drive solution.

Clutches

These guardians of agricultural machinery protect your valuable equipment against overloading – and you, the user, against the great expense that could otherwise result.

Gearboxes

A decisive component in the Walterscheid Drive Line System and one of our specialties. We cooperate closely with the manufacturers of agricultural machinery in this field. For you as a farmer, it's good to know that the driveline comes from a single source.



CONTENT



PTO DRIVE SHAFTS
Page 6



LOCKS
Page 8



**PTO DRIVE SHAFT
GUARD**
Page 10



CLUTCHES
Page 12



INFO
Page 15



PTO DRIVE SHAFTS

Tailored to your requirements:
so everything always runs smoothly

Hopefully. After all, if the PTO drive shaft fails, things can get expensive – or dangerous. That's why this crucial component should always be a quality product! The investment will pay off in the long run.

There's a different, optimum PTO drive shaft configuration for every combination of tractor and implement – which is why we produce a variety of types with different features. The manufacturers make a preliminary choice in cooperation with us.

Safety and operating convenience:
you can replace components

Something many farmers don't know is that they can themselves do something to improve operating convenience and their personal safety after buying a PTO drive shaft:

Do you find greasing too inconvenient?

If so, use cap bottom lubrication and grease conveniently through a small opening in the guard cone.

Or is the lock too awkward for you?

In that case, just switch to the convenient QS lock: push back, hitch, done!



Lubricate just once per season:
with cap bottom lubrication, all you
have to grease is a readily accessible
grease nipple. Large ducts store
plenty of grease. This option is avail-
able for all series.

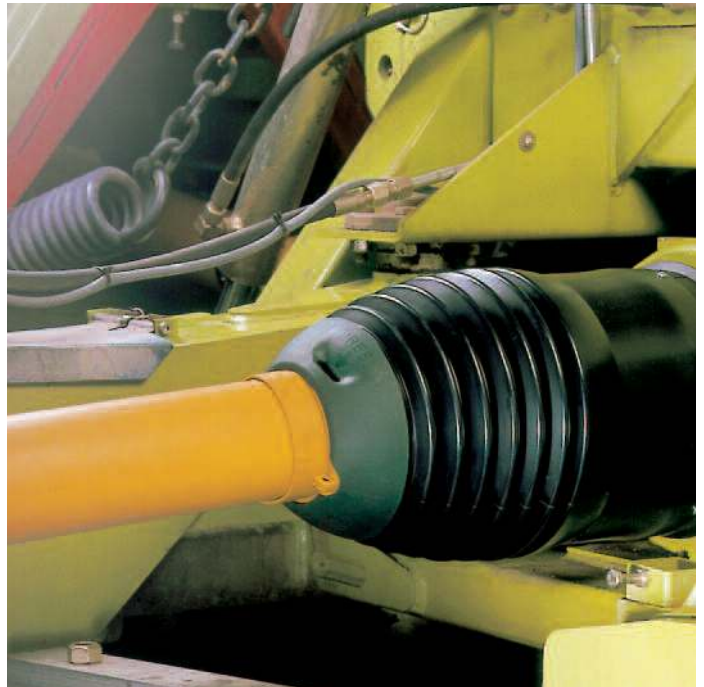

THE RIGHT THING FOR EVERYONE



Depending on the application profile, we offer different designs of universal joint:

- > Simple PTO drive shaft (W)
- > Wide-angle, constant-velocity PTO drive shafts, one wide-angle joint (WWE)
- > Wide-angle, constant-velocity PTO drive shafts, two wide-angle joints (WWZ)

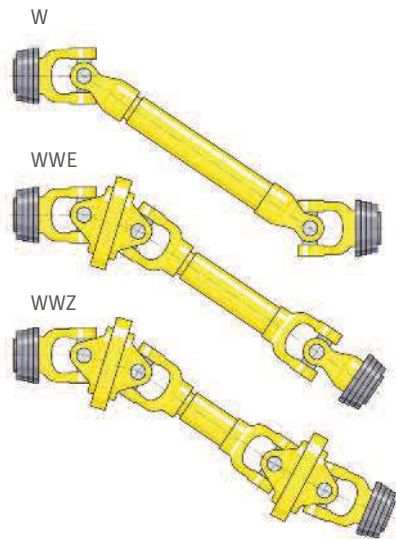

Convenient greasing is achieved thanks to the familiar cap bottom lubrication system (5). Compared to the standard version, Power Drive wide-angle joints only have to be lubricated every 40 hours, instead of every 8.

As individual as your combination

Ever since we began manufacturing PTO drive shafts - and that's more than 50 years ago - we've constantly been incorporating the latest developments in safety engineering and practice in our products. The result is a range of top-quality components that you can use to put together PTO drive shafts to suit every requirement. From the small, economical version and standard features, all the way to heavy-duty combinations for constant use. After all, we know that every combination of tractor and implement has its own peculiarities. And every farmer has his own particular preferences.

High power for constant use

The Power Drive fills the requirements profile of large-scale farmers and contractors. Well-conceived features make the Power Drive a real high-end solution in terms of handling, cost-efficiency and safety. The maintenance effort has been minimised to such an extent that you now only have to lubricate the Power Drive once every 250 hours of operation.

PTO drive shafts in three designs

A normal universal joint may only be angled to a very limited degree and is thus suitable for operation with the joint straight. Wide-angle, constant-velocity PTO drive shafts are a better solution if you have to work with larger angles. We offer these shafts with one or two wide-angle joints. The WWE version is the right choice if one joint is usually straight and the other has to move. In the event of large and unequal operating angles, you'll be on the safe side with the WWZ version, which has wide-angle, constant-velocity joints on both ends. Ask your agricultural machinery dealer about the optimum solution for your particular field of application.

The new power drive wide-angle joint

The new generation of Walterscheid wide-angle joints features a number of technical refinements that result in not only that result in not only a low maintenance requirement, but also a substantial increase in service life.

Longer service life, less maintenance!

High-quality spherical plain bearings (1) and floating disks (2) increase the service life of the guide system. Dirt cannot get in, and grease cannot escape. The central lubrication system (3) supplies the joint with sufficient grease. The crosses are equipped with the blue P-seal.

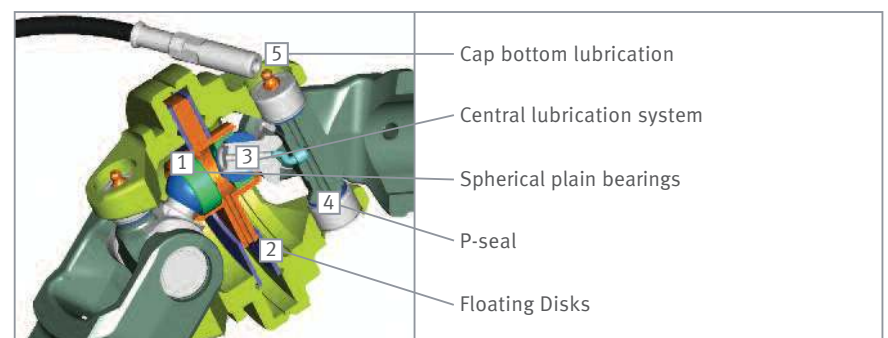

TOP SECURITY

Unbeatably simple handling with the QS lock

For you as the user, the lock is one of the most important details of your PTO drive shaft. After all, you have to operate it day after day when hitching and unhitching. In this context, operating convenience and your safety are of decisive importance. And something else you should know is that you can greatly improve the operating convenience at little expense – just replace the lock! The most convenient solution is the QS lock.





QS lock



AZG lock



ASGE lock



ASG lock



CC lock

YOU HAVE THE CHOICE: QUICK-DISCONNECT LOCKS FOR STANDARDISED POWER TAKE-OFF SHAFT PROFILES

The QS PTO drive shaft lock

is an advanced development of the familiar push-pull lock and available for all sizes. Since the QS yoke can be pre-centred on the power take-off shaft with the lock open, you have both hands free for sliding it on. Engaging of the QS lock is automatic and clearly audible. Safety advantage: no risk of injury due to the master shield and projecting parts, no risk of stalks or clothing being drawn in.

› For series W 2100 – P 700

The AZG lock

is an open design and based on time-proven push-pull lock technology, as used in radial pin clutches.

› For series W 100E – W 400E

The ASGE lock

comes with a plastic collar. It makes handling easy and covers the locking spring.

› For series W 2100 – W 2400

The ASG lock

is the stable metal version of the ASGE without plastic parts. It makes handling easy and covers the locking spring.

› For series W 2500 – P 700

The CC lock

establishes a play-free connection between yoke and power take-off shaft. The clamping cone engages the annular groove on the power take-off shaft.

› For series P 600 – P 700

Yokes equipped with a QD pin lock no longer comply with the European Standards applicable since 2004 and may no longer be used on the tractor side.



PTO DRIVE SHAFT GUARD

Milestones in agritechnical engineering

Walterscheid launched the first fully guarded PTO drive shaft on the market in 1953. Thanks to Walterscheid PTO drive shafts, serious accidents have since become a thing of the past. In the last fifty years, we have continuously made farming even safer and more convenient: with the Tractor Attachment System, various safety clutches or the hydraulically controlled lateral stabiliser – to name but a few of the milestones in agritechnical engineering.

Flexo-element closes the last gap on wide-angle joints

European Standard EN 12965, which has been in force since November 2004, occasioned us to develop our latest innovation: the green flexo-element for wide-angle, constant-velocity PTO drive shafts. The standard prescribes that the gap between the guard cone and the joint may be no larger than 30 mm. With this highly flexible, plastic element, we even close it completely.

Walterscheid launched the first fully guarded PTO drive shaft on the market in 1953. Thanks to Walterscheid PTO drive shafts, serious accidents have since become a thing of the past.





The PTO drive shaft correctly secured with two safety chains



WIDE-ANGLE JOINTS

Standard:
one flexo-element – two safety chains

The new flexo-element protects the master shield on the tractor side against rotation.

- › The risk of objects being drawn in is eliminated.
- › Small openings in the green plastic ensure air exchange and prevent overheating.
- › Coarse dirt no longer gets into the joint, fine particles can flow out.
- › For cleaning or lubrication, you can easily slide the element over the shaft and the cone.

Power Drive:
full guard and flexo-element – no safety chains

- › On this high-end version, profiled tubes are used to prevent rotation of the guard.

SIMPLE PTO DRIVE SHAFT

Standard:
two shields – two safety chains

- › The classical guard is formed by the two shields in combination with the safety chains on both sides. Time-proven and effective.

Power Drive:
full guard – without safety chain

- › The Power Drive with simple joints can be combined with a full guard.
- › It makes the implement-side safety shield and both safety chains superfluous.
- › Dangerous rotation of the complete guard is prevented.
- › To service the PTO drive shaft, you can simply pull the guard cone back.

CLUTCHES

The guardians of agricultural machinery

You'll have an encounter with the clutch on your PTO drive shaft whenever something is wrong. For instance, if you're driving too fast and there's a risk of you overloading the attached implement. That most often happens when you start work, before you've found the optimum working speed. However, overloads also occur when foreign bodies obstruct your implement, or if you try to process too much material at once.

There are various clutch types that manufacturers typically use to equip particular implements. You have experience with your combination and know, for example, how to clear your big baler with the cam-type cut-out clutch. It goes without saying that the output of your tractor must not exceed the maximum force specified by the manufacturer in the user manual.

And if your clutch nevertheless keeps on interrupting your work, the reason could also be that you are using your machine in too high an output range – in other words, simply overtaxing it. For many situations, there are convenient, high-end solutions as well as the standard equipment. Since he has the necessary specialist knowledge, the best thing would be for you to consult your agricultural machinery dealer.

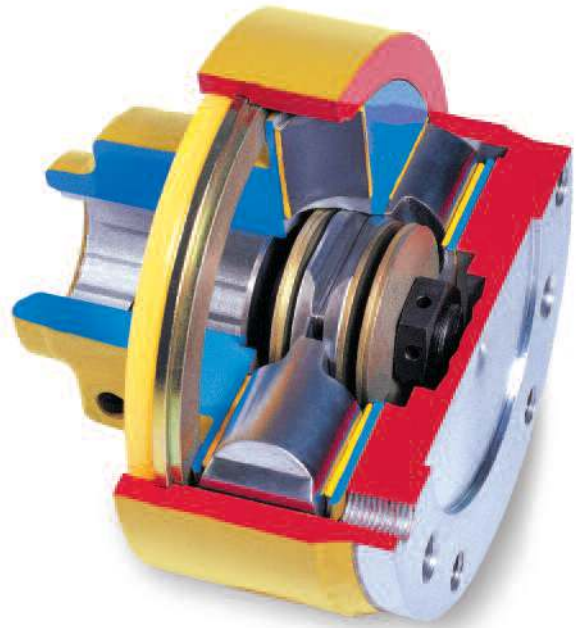



CLUTCHES FOR EVERY REQUIREMENT THE MAIN CLUTCH TYPES AT A GLANCE:

> Cut-out clutches

Typical applications include: self-loading trailers, manure spreaders, big balers, rotary harrows, corn headers, feeders on forage harvesters, snow blowers, etc.

> Friction clutches or combined friction and overrunning clutches

Primarily used on high-density pick-up balers, fans, rotary cultivators or rotary mowers.

> Radial pin clutches

Particularly suitable for manure spreaders and self-loading trailers in the low-end power range, for rotary tedders, rotary windrowers, sugar beet or potato lifters and cutting equipment.

INTEGRATED CUT-OUT CLUTCH: OUR KNOW-HOW FOR YOUR SAFETY!

Walterscheid has always paid particular attention to safety in agritechnical engineering. Integrated safety clutches are one of our specialties. Experience shows that warnings in manuals and on implements are not enough to prevent serious accidents on running big balers, for example. We play on the safe side and develop clutches that interrupt the driveline before you, the operator, enter the danger zone: for instance, by means of sensors on the driver's seat or light barriers in the loading area.

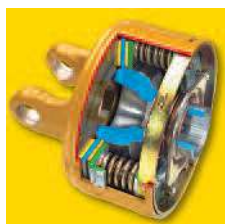
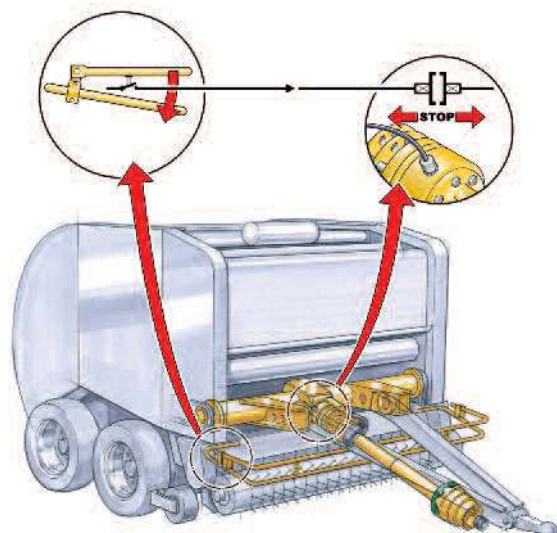

Friction and overrunning clutch



Overrunning clutch



Friction clutch



Shear bolt clutch



Radial pin clutch



Cut-out clutches

Maintenance notes

Friction clutches always have to be released after extended periods of non-use. The clutch then has to be turned when released in order to free any friction linings that may have become stuck to the opposite surfaces.

Cut-out clutches and combined friction and overrunning clutches should be checked regularly for play between the hub and the implement PIC. If there is too much play, the PTO drive shaft will begin to "thrash".



EXPLOIT OUR EXPERIENCE



You can buy our products from 20,000 selected, specialist agritechnical dealers throughout the world. There's bound to be one near you.

Symbol for reliability

When you invest in the safety of your driveline, you're guaranteed to be doing the right thing. So, decide on Walterscheid products!

- › PTO drive shafts, clutches, gearboxes and their components are designed for long-term use.
- › All wear parts are easily replaced.
- › You can upgrade or convert your equipment with individual components to suit your needs.
- › You'll find the right product for every power range.

Dealer network: ready and waiting worldwide

We see ourselves as service partners for dealers and farmers alike. Our logistical and technical dealer support benefits you as the user:

- › We regularly inform our sales partners about technical innovations. Consequently, your dealer can tell you in detail which part is the right one for you.
- › Your dealer can also install or repair parts for you.
- › He also has rapid access to the 24-hour spare parts service, thus minimising downtimes in the event of repairs.
- › If you're in a hurry and want to install the part yourself, the dealer can also arrange for it to be delivered directly to you.
- › Using the electronic spare parts catalogue at www.walterscheid.com, you can also identify spare parts yourself and order them from your dealer.

We reserve the right to change design without prior consultation. Use products only for specified applications. We only guarantee a constant quality. Reproduction, even in part, is only authorized with the written consent of Walterscheid GmbH.



WALTERSCHEID

WALTERSCHEID GMBH

Hauptstraße 150

D-53797 Lohmar

Tel.: +49 2246 12-0

Fax: +49 2246 12-3501

www.walterscheid.com

With the compliments of:

