

**MONTAGE- UND BETRIEBSANLEITUNG
INSTALLATION AND OPERATING INSTRUCTIONS
INSTRUCTIONS DE MONTAGE ET D'UTILISATION**

18.03.2022

ZUGKUGELKUPPLUNG ZKK80-115

COUPLING HEAD ZKK80-115

ACCOUPLLEMENT À BOULE ZKK80-115

WICHTIGE HINWEISE:

siehe separates Dokument BA_TASC_400002, www.walterscheid.com/downloads/

IMPORTATANT NOTES:

see separate document BA_TASC_400002, www.walterscheid.com/downloads/

NOTES IMPORTANTES:

voir document séparé BA_TASC_400002, www.walterscheid.com/downloads

COUPLING HEAD ZKK80-115

1. DESIGNATIONS AND TECHNICAL DATA:

APPLICATION:

For use on agricultural or forestry trailers.

TYPE APPROVAL:

Connecting device acc. to regulation (EU) 2015/208: Coupling head

Type approval mark:



00678ND

CHARACTERISTIC VALUES:

- > Adm. D-value: 102,4 kN
- > Adm. vertical load: 4000 daN (kg)

VERSIONS:

The coupling head can be supplied with two differently machined flanges. They differ in the angle of the mounting surface to the horizontal plane:

Type/Version	Angle mounting surface	see
ZKK80-115	0° (flat)	Figure 1
ZKK80-115W	8,2° (angular)	Figure 2

COUPLING BALLS:

The coupling ball (also called spherical cap) is suitable for connection with coupling balls 80 according to ISO 24347. When assembling the towing vehicle, it must be ensured that the coupling ball attached to the towing vehicle for connection to the coupling head is type-approved or, in the area of application of the Road Traffic Licensing Regulation (StVZO), has an individual certificate. In particular, the coupling balls must ensure the required characteristic values and the required horizontal, vertical and axial swivel angles of the drawbar coupling.



NOTE:

If the valid national approval regulations of the respective country of use require additional official approvals for using these parameters, such approvals must be applied for.



IMPORTANT:

To avoid injury, protective gloves, safety glasses and safety shoes must be worn during all dismantling/ assembly actions described in this chapter.



Environment:

Lubricants can enter the environment. Environmental pollution: Collect, store and correctly dispose of lubricants in suitable containers.

2. INSTALLATION:

INSTALLATION OF THE COUPLING HEAD:

**NOTE:**

The pertinent regulations (e.g. Accident Prevention Regulations for Vehicles) and the attachment guidelines of the vehicle manufacturers must be observed when installing the coupling head!

The attachment of the coupling to the vehicle must be carried out in accordance with the requirements of regulation (EU) 2015/208, Appendix 34.

**NOTE:**

Official national regulations must be observed. For example: in Germany the obligations §13 FZV regarding the data in the car license concerning the permissible trailer weight as well as the permissible vertical load must be considered.

The coupling head can be mounted directly on the frame parts or on the towing device of the trailer via a mounting plate.

**IMPORTANT:**

The mounting plate and its welded seam connection must be sufficiently dimensioned to transmit the characteristic values approved for the coupling head. During assembly, the contact surfaces of the mounting plate and the flange of the coupling head must be clean and free of paint and grease. Priming is permissible.

In the centre of the flange a heart bolt is fitted for power transmission. The bolt diameter is $\text{Ø}40 \text{ h}9$. The coupling head is fixed with 6 bolts ISO 4014 – M20 in the quality of 10.9. They must be tightened crosswise. As a rule, the fastening bolts are not included in the scope of delivery of the coupling head, therefore the trailer/drawbar manufacturer's specifications for fastening must be observed.

If there are no specifications see separate document BA_TASC_400038, www.walterscheid.com/downloads/

3. OPERATION:

The coupling head is suitable for connection with coupling balls 80 according to ISO 24347. The coupling balls in combination with the retainer must in particular ensure the required swivel angles of the coupling head of +/- 60 degrees in the horizontal direction and +/- 20 degrees in the vertical and axial direction. When the towing vehicle and trailer are in a horizontal position, the coupled coupling head must be approximately horizontal to the roadway (angular deviation from the horizontal upwards and downwards not more than 3°) in order not to obstruct the customary pivoting angles between the coupling ball and the coupling head.

**WARNING:**

The pertinent safety regulations must be observed when coupling and uncoupling.

No one may stand between the vehicles. The coupling may only be operated in locked condition.

4. MAINTENANCE:

As part of the vehicle maintenance, the contact surfaces at the coupling point must be lubricated and the fastening screws of the coupling head must be checked for tightness using a torque spanner. Loose bolts (tightening torques lower than under point 2) must be replaced with new bolts. Repairs and welding work on the coupling head are not permitted. Damaged, deformed or worn coupling heads must be replaced. The permissible longitudinal and lateral play between the coupling ball and the coupling head

may be 1.5 mm, the permissible vertical play between the coupling head and the coupling ball retainer may be 5 mm. If the wear limits are exceeded, the worn parts must be replaced.

CARE

- > If there is a grease nipple on the coupling head, the ball can be supplied with grease via the central lubrication system.
- > If possible, avoid cleaning with high-pressure cleaners. If this is done, the coupling ball must be greased immediately.
- > For relubrication, remove the old grease and lubricate the coupling head with fresh grease. For lubrication use a water-resistant, multi-purpose grease (Grease type: lithium saponified, consistency class: NL-GI2).

WEAR LIMITS:

Designations	Nominal dimension	Wear limit dimension	Gauge
Coupling head inside	80,5 mm	82,2 mm	X
Coupling head outside	124 mm	123 mm	

(see also VdTÜV-Merkblatt 712).

For convenient checking of some wear limits, a separately available Walterscheid test gauge can be used.

If the wear limits are reached, the ball coupling and/or the ball must be replaced.

If the height play of the coupled coupling head is more than 5 mm, the corresponding parts such as the retainer, coupling ball or coupling head must be replaced.



IMPORTANT:

Use only original Walterscheid spares when replacing parts. If the vehicle owner does not have the appropriate skilled workers and the necessary technical equipment, the replacement may only be performed by a specialist workshop.



WARNING:

SAFETY NOTES:

- > The user is obliged to always operate the coupling head in perfect condition and to forbid its use by unauthorised persons.
- > The loads indicated on the type plate may not be exceeded.
- > Unauthorised conversion or modification of the coupling head is not permitted.

5. CALCULATION OF CHARACTERISTIC VALUES FOR CORRECT OPERATION OF THE COUPLING HEAD ON AGRICULTURAL AND FORESTRY TRAILERS

See attachment or separate document BA_TASC_400029, www.walterscheid.com/downloads

BILD 1
FIGURE 1

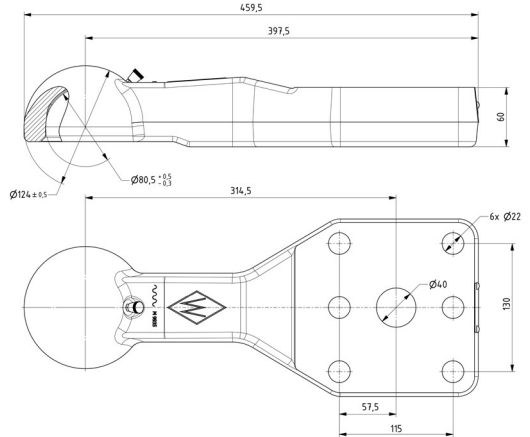

Zugkugelkupplung ZKK80-115
Coupling head ZKK80-115
Accouplement à boule ZKK80-115

BILD 2
FIGURE 2

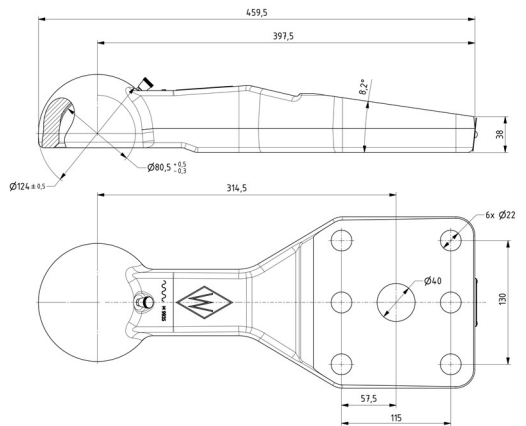

Zugkugelkupplung ZKK80-115W
Coupling head ZKK80-115W
Accouplement à boule ZKK80-115W