

**MONTAGE- UND BETRIEBSANLEITUNG
INSTALLATION AND OPERATING INSTRUCTIONS
INSTRUCTIONS DE MONTAGE ET D'UTILISATION**

06.12.2021

ZAPFWELLENSCHUTZ ERSATZTEIL – KIT (ZWS ET-KIT)

MASTER SHIELD SPARE PART KIT (ZWS ET-KIT)

KIT DE RECHANGE POUR LA PROTECTION DE LA PRISE
DE FORCE (ZWS ET-KIT)

WICHTIGE HINWEISE:

siehe separates Dokument BA_TASC_400002, www.walterscheid.com/downloads/

IMPORTATANT NOTES:

see separate document BA_TASC_400002, www.walterscheid.com/downloads/

NOTES IMPORTANTES:

voir document séparé BA_TASC_400002, www.walterscheid.com/downloads/

MASTER SHIELD SPARE PART KIT (ZWS ET-KIT)

OPERATING RANGE:

The PTO master shield spare part kit enables the exchange of damaged original PTO master shield.

SCOPE OF DELIVERY:

(see figure 1)

The PTO master shield spare part kit includes the actual replacement for the PTO master shield, two clamping brackets, two hexagon head bolts M8x20 – ISO 4017 and two locking nuts M8 – ISO 7040. Rivets for the type plate are also included, see paragraph 3.



IMPORTANT:

To avoid injury, protective gloves, safety glasses and safety shoes must be worn during all dismantling/ assembly actions described in this chapter.

Environment:

Lubricants can enter the environment. Environmental pollution: Collect, store and correctly dispose of lubricants in suitable containers.

2. INSTALLATION:

(see figure 2 and 3)



NOTE:

The pertinent regulations (e.g. Accident Prevention Regulations for Vehicles) and the attachment guidelines of the vehicle manufacturers must be observed when installing the kit!



IMPORTANT:

If the vehicle owner does not have the appropriate skilled workers and the necessary technical equipment, the installation may only be performed by a specialist workshop. Walterscheid does not assume responsibility for the execution of the above mentioned work.

- > The damaged original PTO master shield has to be removed in the first step. In doing so, damage to the 25 mm round steel and spring **must** be avoided.
- > The two clamping brackets are hooked up on the 25 mm round steel, and subsequently the replacement for the PTO master shield has to be slid into the towing frame (fig. 2).
- > It must be ensured that the right side clamping bracket tightly rests alongside the catch spring, and the noses of the PTO master shield reach into the notches of the clamping bracket (fig. 3).
- > As a final step, the PTO master shield and the clamping brackets are tightly bolted together with the M8 screws and nuts provided (tightening torque: 25 Nm).



NOTE:

On older towing frames, two tubes can be welded onto the original PTO master shield instead of a single piece bended master shield. In that case, the (rigid) sheet metal in the back has to be removed prior to mounting the spare part kit according to figure 4 in order to provide the space for the new PTO master shield.

3. REGULATORY REQUIREMENTS:

On many models of type-approved towing frames, type plates are riveted onto the rotatable PTO master shield. In these cases, a replacement requires the operator to present an affirmation in lieu of an oath (respective form enclosed in assembly instructions) which confirms that the respective towing frame is in use and the PTO spare part kit will only be attached to this towing frame. Furthermore, it has to be confirmed that the original type plate will be attached to the new PTO master shield in the same place. For this purpose, the enclosed rivets shall be used. Please also see the assembly and operation instructions of the towing frame.

In case of the original type plate being lost, a replacement type plate has to be mounted. For this purpose, please contact Walterscheid GmbH.

Contact can be established via our service partner in Dingelstädt.

Product hotline: +49 (0) 36075 / 573-0

Contact form: <http://walterscheid-group.com/contact>

The following table shows the availability of PTO master shield spare part kits:

TYPE TOWING FRAME	NATIONAL TYPE-APPROVAL	EUROPEAN TYPE-APPROVAL
KU 303	M 9618	e1*2009*144/2013/8*0163
KU 303N	M 10066	e1*2009*144/2013/8*0545 e1*2015/208*2015/208ND*00271
KU 304	M 9760	e1*2009*144/2013/8*0286

**IMPORTANT:**

Use only original Walterscheid spares when replacing parts. If the vehicle owner does not have the appropriate skilled workers and the necessary technical equipment, the replacement may only be performed by a specialist workshop.

**WARNING:****SAFETY NOTES:**

- > The user is obliged to always operate the coupling in perfect condition and to forbid its use by unauthorised persons.
- > The loads indicated on the type plate may not be exceeded.
- > Unauthorised conversion or modification of the coupling (Exception Figure 4) is not permitted.

Bild 1 – ZWS ET-Kit
Figure 1 – ZWS ET-Kit



Bild 2 – Montage
Figure 2 – Installation
Figure 2 – Montage



Bild 3 – Montage
Figure 3 – Installation
Figure 3 – Montage

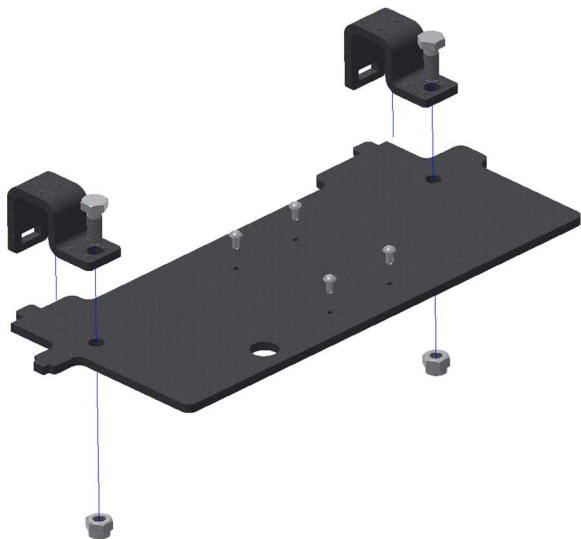

Bild 4 – Montage (Bearbeitung Zapfwellschutz, falls erforderlich)
Figure 4 – Installation (machining of PTO-guard, if needed)
Figure 4 – Montage (Traitement de la protection de la prise de force, si nécessaire)



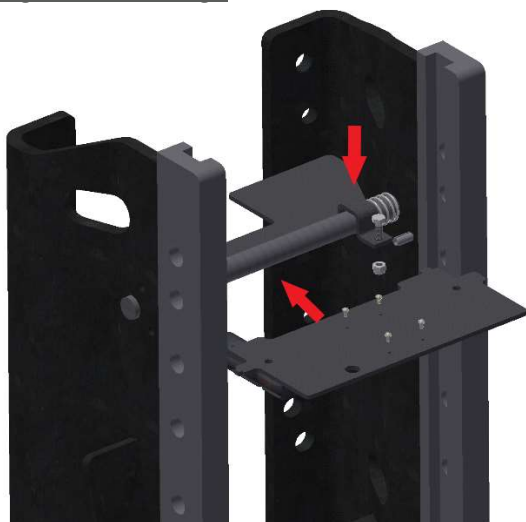

Affirmation in lieu of an oath

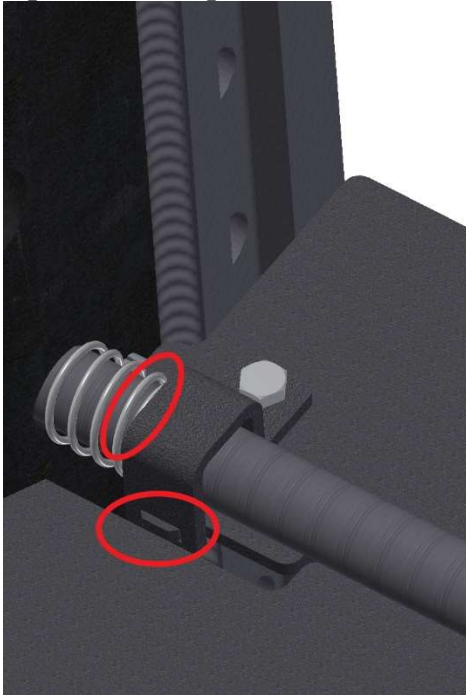
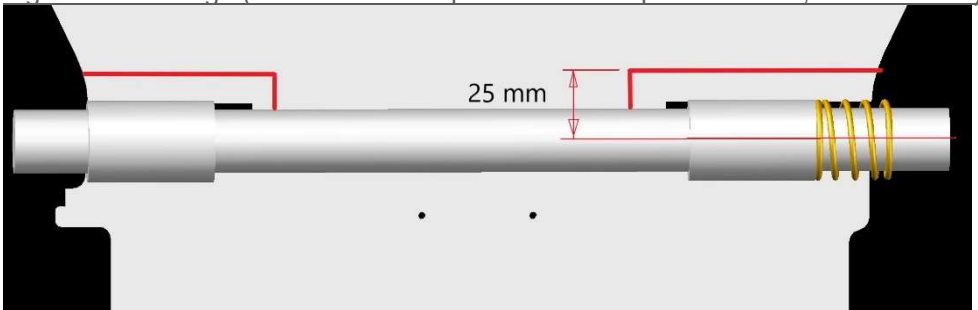
For your files!
To be provided to the technical service if applicable.

I hereby confirm,

(name and address)

that I operate the towing frame

(type and model)

with the authorisation number

(type approval number(s))

on the vehicle

(brand and name).

I also confirm that I will exclusively mount the PTO - spare part master shield that was delivered to me onto the above mentioned towing frame, and that I will attach the existing type plate to this PTO - spare part master shield according to assembly instructions. (Note: In case of non-compliance with assembly instructions, authorisation for the operation of the device will expire!)

(Place, date, signature)

**Diese Seite bleibt frei.
This page remains blank.
Cette page reste vide**

Affirmation in lieu of an oath

Please send back to: **Walterscheid GmbH**
 Hauptstraße 150
 53797 Lohmar
 Germany
 Abteilung: Interner Vertrieb

I hereby confirm,

(name and address)

that I operate the towing frame

(type and model)

with the authorisation number

(type approval number(s))

on the vehicle

(brand and name).

I also confirm that I will exclusively mount the spare master shield that was delivered to me onto the above mentioned hitch frame, and that I will attach the existing type plate to this spare master shield according to assembly instructions. (Note: In case of non-compliance with assembly instructions, authorisation for the operation of the device will expire!)

(Place, date, signature)

**Diese Seite bleibt frei.
This page remains blank.
Cette page reste vide**