

**MONTAGE- UND BETRIEBSANLEITUNG
INSTALLATION AND OPERATING INSTRUCTIONS
INSTRUCTIONS DE MONTAGE ET D'UTILISATION**

16.08.2021

KUGELKUPPLUNG KB (KUGELBOCK) 8300K

BALL COUPLING TYPE KB 8300K

BOULE D'ATTELAGE KB 8300K

WICHTIGE HINWEISE:

siehe separates Dokument BA_TASC_400002, www.walterscheid.com/downloads/

IMPORTATANT NOTES:

see separate document BA_TASC_400002, www.walterscheid.com/downloads/

NOTES IMPORTANTES:

voir document séparé BA_TASC_400002, www.walterscheid.com/downloads/

BALL COUPLING KB 8300K

1. DESCRIPTION:

The ball coupling dimensions and field of application complying with ISO 24347, VO (EU) 2015/208 and regulation UN ECE R147, class a80.

In its normal state, the device is in coupled and locked position.

Only for connection with coupling heads 80 (ball-type trailer shank) according to ISO 24347 or UN ECE R147, class b80.

The KB 8300K ball-type coupling can only be used in towing frames with quick-adjust height adjustment.

OPERATING RANGE:

For use on agricultural or forestry vehicles, self-propelled work machines or trailers.

TYPE APPROVAL:

Connecting device according to VO(EU)2015/208: ball coupling

CHARACTERISTIC VALUES:

- > admissible D-value: 102 kN
- > admissible vertical load: 4000 daN (kg)

Type approval sign:



00049ND



NOTE:

If the valid national approval regulations of the respective country of use require additional official approvals for using these parameters, such approvals must be applied for.

For use of the coupling above the PTO, attention should be paid to the vehicle manufacturer's data regarding vertical loads.



IMPORTANT:

Attention must be paid to the D value and the maximum vertical load of the towing frame in this context. The lower value applies in each case.

VERSIONS AND DIMENSIONS:

(See Figure 1)

The ball coupling can be supplied in various dimensions according to the table below.

| Type / Versions | Total width Dim. A | Guide width Dim. B | Pin-Ø-Dim. C | Guide spacing in towing frame | Guide width in towing frame | Hole -Ø in towing frame |
|-----------------|--------------------|--------------------|--------------|-------------------------------|-----------------------------|-------------------------|
| | [mm] | [mm] | [mm] | [mm] | [mm] | [mm] |
| KB 8329K | 329 | 31,7 | 25,0 | 330 | 32 | 26 |
| KB 8335K | 335 | 29,7 | 22,6 | 336 | 30 | 23 |
| KB 8389K | 389 | 31,7 | 25,0 | 390 | 32 | 26 |

Table 1



IMPORTANT:

To avoid injury, protective gloves, safety glasses and safety shoes must be worn during all dismantling/ assembly actions described in this chapter.

Environment:

Lubricants can enter the environment. Environmental pollution: Collect, store and correctly dispose of lubricants in suitable containers.

2. INSTALLATION:

(See Figure 2)



NOTE:

The pertinent regulations (e.g. Accident Prevention Regulations for Vehicles) and the attachment guidelines of the vehicle manufacturers must be observed when installing the coupling!

The attachment of the coupling to the vehicle must be carried out in accordance with the requirements of regulation (EU) 2015/208, Appendix 34.



NOTE:

Official national regulations must be observed. For example: in Germany the obligations §13 FZV regarding the data in the car license concerning the permissible trailer weight as well as the permissible vertical load must be considered.

ATTACHMENT OF THE BALL COUPLING TO THE TOWING FRAME:

- > Remove a possibly existing fall protection in the coupling frame (screw M12, spring pin or similar).
- > Remove the linch pins (4) of the locking pins (3) and pull out the pins.
- > Push ball-type coupling (1) from above into the slots of the guide rails of the coupling frame.
- > Hold on the desired height position in the coupling frame. Fix the locking pins (3) by the linch pins (4) reciprocally.
- > The guide of the slider (120 mm long) must not project beyond the guide slots of the frame, both above and down.



WARNING:

The pertinent safety regulations must be observed when coupling and uncoupling.

No one may stand between the vehicles. The coupling may only be operated in locked condition.

3. DESCRIPTION, OPERATION AND MAINTENANCE:

See attachment or separate document BA_TASC_400028, www.walterscheid.com/downloads/



WARNING:

SAFETY NOTES:

- > The user is obliged to always operate the coupling in perfect condition and to forbid its use by unauthorised persons.
- > The loads indicated on the type plate may not be exceeded.
- > Unauthorised conversion or modification of the coupling is not permitted.

4. CALCULATION OF CHARACTERISTIC VALUES FOR CORRECT OPERATION OF THE COUPLING ON AGRICULTURAL AND FORESTRY VEHICLES

See attachment or separate document BA_TASC_400029, www.walterscheid.com/download

4. DETERMINATION DES VALEURS CARACTERISTIQUES POUR LE FONCTIONNEMENT DE L'ATELAGE SUR LES VEHICULES AGRICOLES ET FORESTIERS :

Voir annexe ou document séparé BA_TASC_400029, www.walterscheid.com/downloads/

BILD 1
FIGURE 1

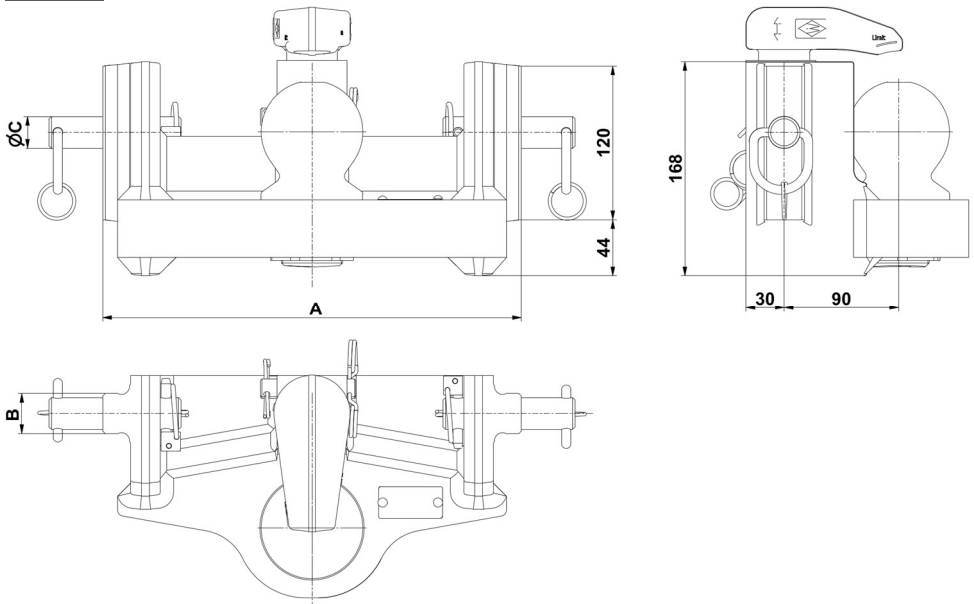

Abmessungen
Dimensions

BILD 2
FIGURE 2

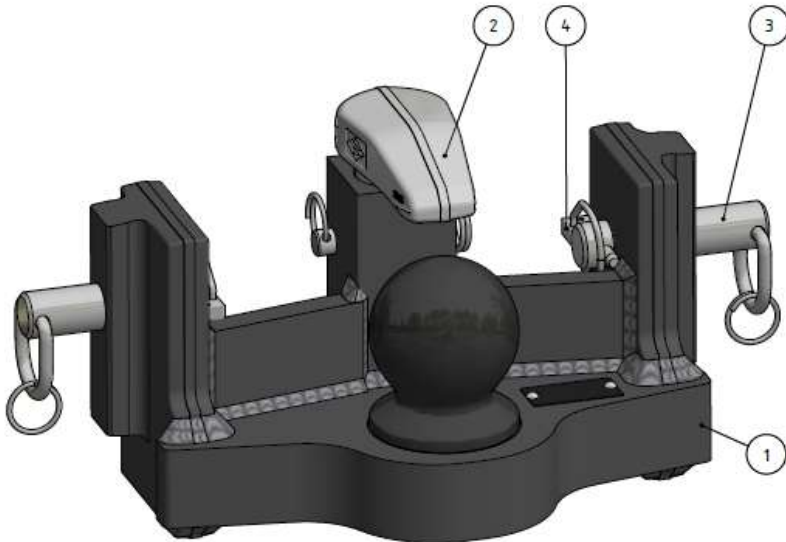

Kugelbock KB 8329K
Ball-type coupling KB 8329K
Boule d'attelage KB 8329K

Legende:

- 1 Kugelbock
- 2 Niederhalter
- 3 Absteckbolzen
- 4 Klappstecker

Legend:

- 1ball-type coupling
- 2retainer
- 3locking pin
- 4linch pin

Légende:

- 1 ...boule d'attelage
- 2 ...dispositif de retenue
- 3 ...boulon d'arrêt
- 4 ...goupille