

**MONTAGE- UND BETRIEBSANLEITUNG
INSTALLATION AND OPERATING INSTRUCTIONS
INSTRUCTIONS DE MONTAGE ET D'UTILISATION**

01.12.2021

NICHTSELBSTTÄTIGE ANHÄNGEKUPPLUNG KU 5410/750

NON-AUTOMATIC TRAILER COUPLING KU 5410/750

**ATTELAGE DE REMORQUE NON AUTOMATIQUE KU
5410/750**

WICHTIGE HINWEISE:

siehe separates Dokument BA_TASC_400002, www.walterscheid.com/downloads/

IMPORTATANT NOTES:

see separate document BA_TASC_400002, www.walterscheid.com/downloads/

NOTES IMPORTANTES:

voir document séparé BA_TASC_400002, www.walterscheid.com/downloads/

NON-AUTOMATIC TRAILER COUPLING KU 5410/750

1. TECHNICAL DATA AND DESIGNATIONS:

DESCRIPTION:

(See Figure 1)

The coupling is a non-automatic trailer coupling, its clevis dimensions and field of application complying with DIN 11028 as well RREG 2009/144/EC, VO (EU) 2015/208 and regulation UN ECE R147, class c40.

The automatic trailer coupling can be pivoted through 360°, the torque required for this purpose being 100 - 150 Nm.

OPERATING RANGE:

For use on agricultural or forestry vehicles, self-propelled work machines or trailers.

TYPE APPROVALS AND CHARACTERISTIC VALUES:

EU- TYPE APPROVAL:

Connecting device according to VO(EU)2015/208: clevis type mechanical coupling

CHARACTERISTIC VALUES:

- > Adm. D-Value: 60,0 kN
- > Adm. vertical load: 2000 daN (kg)

Type approval mark:



00528ND



NOTE:

If the valid national approval regulations of the respective country of use require additional official approvals for using these parameters, such approvals must be applied for.

For use of the coupling above the PTO, attention should be paid to the vehicle manufacturer's data regarding vertical loads.

VERSIONS (= ORDER DESIGNATION):

The hitch is supplied in two different factory assembly situations. As standard, it is set up for fixing holes on the vehicle with a vertical spacing of 119 mm, version 750. Fixing holes with a vertical spacing of 105 mm can be set by switching the right and left bearing plates during assembly, version 730 (see figure 2).

The couplings are available in versions NB (normal pin), ZB (draw pin) and STB (socket pin).

Designations are always expressed as: **KU5410**/xxxYYY, with xxx representing the version (730 or 750) and YYY the pin.

Example:

KU5410/750ZB335

KU5410 = non automatic coupling of the KU5410 series

750 = assembly situations with a vertical spacing of 119 mm

ZB335 = draw pin with length of 335 mm

TRAILER RINGS:

All versions are suitable for connection to trailer rings according to ISO 5692-1, ISO 8755 und ISO 5692-2.

**IMPORTANT:**

To avoid injury, protective gloves, safety glasses and safety shoes must be worn during all dismantling/ assembly actions described in this chapter.

Environment:

Lubricants can enter the environment. Environmental pollution: Collect, store and correctly dispose of lubricants in suitable containers.

2. INSTALLATION:

(See Figure 1)

**NOTE:**

The pertinent regulations (e.g. Accident Prevention Regulations for Vehicles) and the attachment guidelines of the vehicle manufacturers must be observed when installing the coupling!

The attachment of the coupling to the vehicle must be carried out in accordance with the requirements of regulation (EU) 2015/208, Appendix 34.

**NOTE:**

Official national regulations must be observed. For example: in Germany the obligations §13 FZV regarding the data in the car license concerning the permissible trailer weight as well as the permissible vertical load must be considered.

ATTACHMENT OF THE COUPLING:

- > Hold the coupling with the fixing holes in line with the corresponding holes in the bracket on the vehicle.
- > Insert the fixing pins (not included in the scope of supply – part of the vehicle) through the hitch and the bracket on the vehicle.
- > Secure the pins with the grip clips or linchpins provided (not included in the scope of supply).

**WARNING:**

The pertinent safety regulations must be observed when coupling and uncoupling.

No one may stand between the vehicles. The coupling may only be operated in locked condition.

3. DESCRIPTION, OPERATION AND MAINTENANCE:

See attachment or separate document BA_TASC_400026, www.walterscheid.com/downloads/

**WARNING:****SAFETY NOTES:**

- > The user is obliged to always operate the coupling in perfect condition and to forbid its use by unauthorised persons.
- > The loads indicated on the type plate may not be exceeded.
- > Unauthorised conversion or modification of the coupling is not permitted.

4. CALCULATION OF CHARACTERISTIC VALUES FOR CORRECT OPERATION OF THE COUPLING ON AGRICULTURAL AND FORESTRY VEHICLES

See attachment or separate document BA_TASC_400029, www.walterscheid.com/downloads

BILD 1
FIGURE 1



KU5410/750ZB335

BILD 2
FIGURE 2

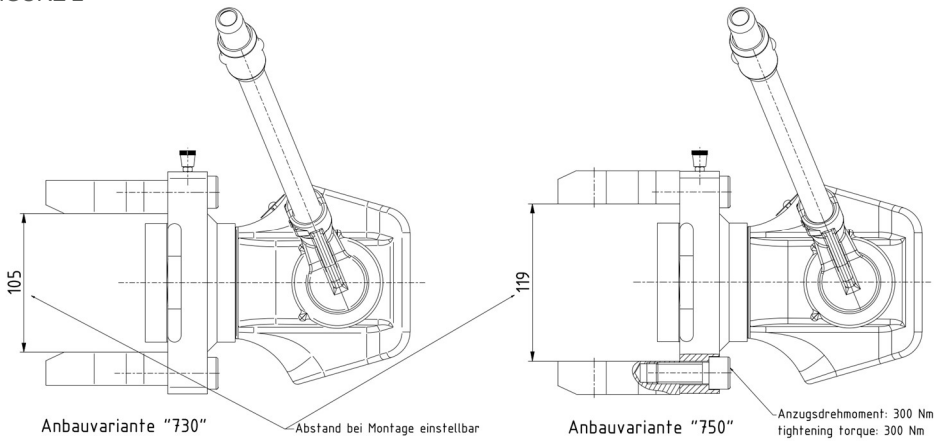

KU5410/730ZB335 & KU5410/750ZB335