

BOHRUNG FÜR PROFILROHRSCHMIERUNG

Bohrung für Profilrohrschmierung positionieren

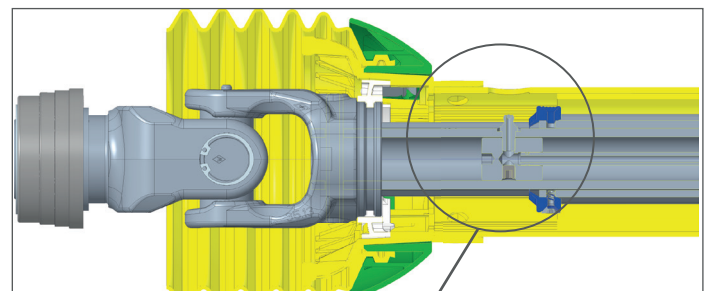
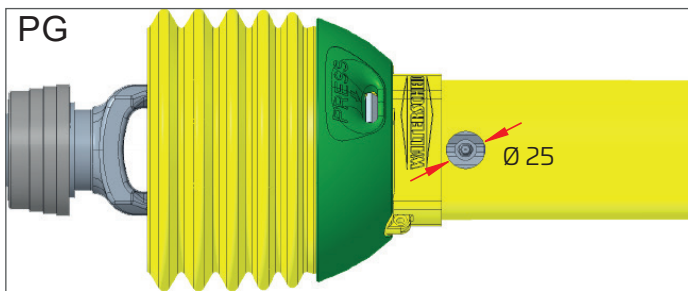

PG25 L = 45 mm

PG30 L = 60 mm

Ø Bohrung = 25 mm

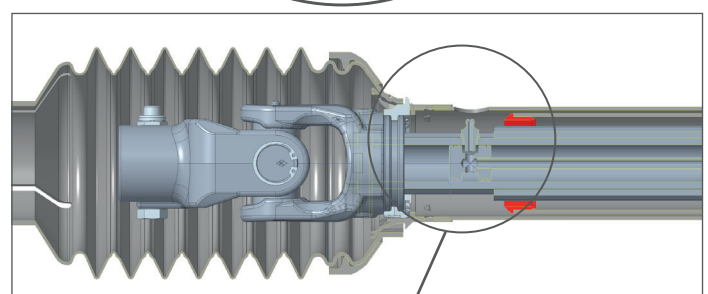
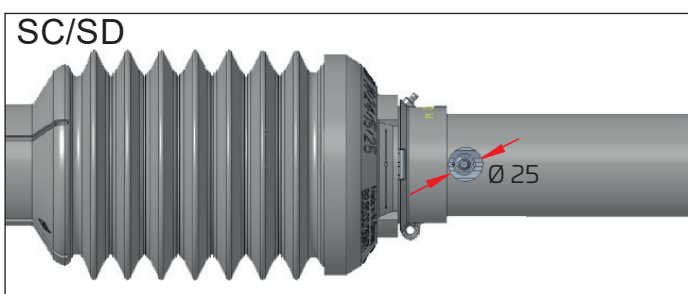
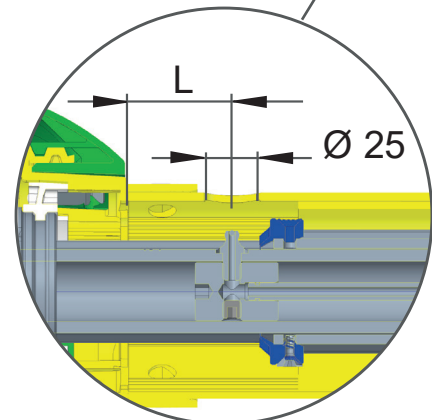

SC/SD25 L = 45 mm

Ø Bohrung = 25 mm

